

FA17 IceFree Wind Speed Sensor



Products description and application

FA17 wind speed sensor is a maintenance free and IceFree sensor, designed for freezing rain, sand, extreme cold and other harsh environments such as wind power, high way and railway meteorological monitoring, disaster prevention system application. Product has the anti-freezing capacity by using 90W high efficiency heating system. The sensor has multi-layer sand-proof and dust-proof structure design, effectively protects the rotation performance of the bearing. Metal body with surface oxidation treatment, strong wind resistance, corrosion resistance and wear resistance.



Features

- High efficiency heating system, melting ice in -40°C ¹.
- Two stage temperature control system, three stage heat insulation system and three layer sand proof design, use high temperature resistance bearing, guarantee the performance and lifetime of bearing ².
- Based on ANSYS CFX wind cup structure design, compatible with small distance constants and high efficiency ice melting performance.
- Adopt non-contact magnetic measuring technology, high precision and strong anti-interference ability.
- Optimized heating system, heating power consumption decreased by 25% ³.

1. Test condition: MIL-STD-810G: expose the sensor in -40°C environment, depth of wind cup ice $>6\text{mm}$, start sensor heating, environment temperature remain the same, wind cup start to run in 1 minute, ice melting in 15 minutes.

2. Patent number: CN108333386A

3. Comparing with Nanhua model FA15 sensor

General Specifications

Electrical		Mechanical	
Rated voltage	DC18V~30V ¹	Housing material	Aluminum alloy/ Hard anodizing
Operating current	Max. 50mA ²	Wind cup	Aluminum alloy/ Hard anodizing
Heating voltage	DC24V \pm 10%	Bearing	SS 440C
Heating power	90W	Humidity	0%~100%RH
Heating type	Mica heating ³	Operating temperature	Ta: -40°C ~ $+70^{\circ}\text{C}$
Lightning surge	IEC 61000-4-5 4kV /2kA	IP rate	IEC 60529 IP65
Electrostatic discharge	IEC 61000-4-2 air discharge 15kV IEC 61000-4-2 contact discharge 8kV	Wiring	Aviation socket ⁴
		Housing color	RAL7013 gray
		Weight	0.5kg
Meteorological			
Starting threshold	0.35m/s	Instantaneous wind speed	QX/T 51-2007 average wind speed of 3 seconds
Anti-wind level	$>70\text{m/s}$		
Range	$0\sim 70\text{m/s}$ ⁵		
Accuracy	$\pm 0.5\text{m/s}$ ($V_L < 16\text{m/s}$) $\pm 3\%$ ($16\text{m/s} \leq V_L \leq 60\text{m/s}$) $\pm 5\%$ ($V_L > 60\text{m/s}$)		
Resolution	0.1m/s		

1. Rated voltage, see How to Order.

2. Current at signal end.

3. When environmental temperature $\leq 3^{\circ}\text{C}$, start the heating, when temperature $\geq 10^{\circ}\text{C}$, stop the heating.

4. Lead wire type, see How to Order

5. Wind range, see How to Order

FA17 IceFree Wind Speed Sensor



Mounting dimensions

Unit: mm

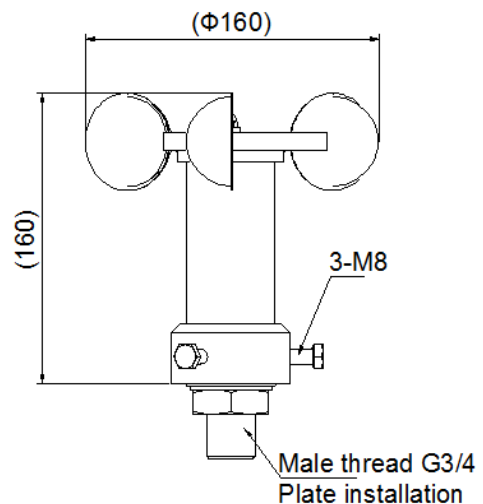
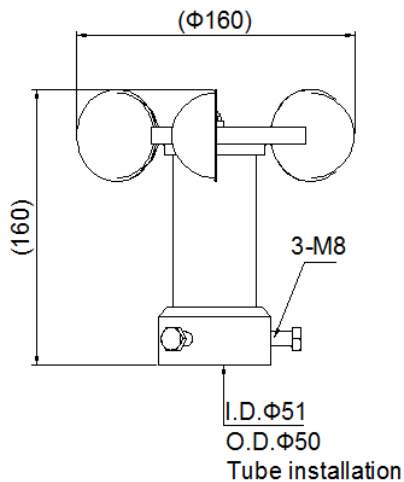

Mast tube mount

1. Connect and fix the aviation plug and socket.
2. Mount product on the top of equipment with 3 nos. M8 screws.

G3/4" thread mount

1. Connect and fix the aviation plug and socket.
2. Fix product on mast, first G3/4" internal serrated lock washer and G3/4" hex nut.
2. Mount and fix the product on adapter by using 3 nos. M8 screws.

Caution: Mount the product on a horizontal level, wind cups on the top, fix product well to prevent drop.
Product should be mounted in lightning protection area LPZ 0B, connect shielded layer to earth.

Wiring diagram

- 棕(Brown) VCC
- 白(White) GND
- 蓝(Blue) Signal +
- 黑(Black) Signal -
- 灰(Grey) Heating DC24V +
- 粉(Pink) Heating DC24V -
- 黄绿(Yellow green) PE

It is recommended to use RVVP/6 core/4C*0.3mm² +2C*1 mm²/copper core/high and low temperature resistant shielding cable, maximum communication distance is 1000m.

Caution:

1. Ensure cable connection is correct before power on.
2. Cable shield layer and housing must be well grounded.
3. Actual communication distance is in accordance with onsite environment.

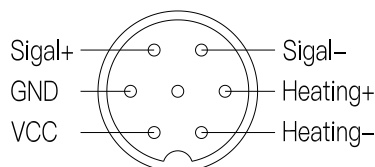

Aviation socket

FA17 IceFree Wind Speed Sensor



Protocol

RS485 protocol (Baud rate: 9600bit/s(factory setting), 8bit data, no parity check, one stop bit.)

Factory setting baud rate: 9600bit/s

Factory setting wind speed sensor address: 21H

Factory setting wind direction sensor address: 23H

1 Protocol description

1.1 Query wind speed data

1.1.1 Data definition (default address: 21H):

Command: xxH 04H 00H 06H 00H 01H CRCL CRCH

Response: xxH 04H 02H xxH xxH CRCL CRCH

1.1.2 Byte definition

xxH is slave address in the command, 04H is function code, 00H, 06H are the high and low address of the first register, 00H, 01H are the high and low quantity of register, CRCH, CRCL are the high and low of previous six bytes' CRC check code.

xxH is salve address in the response, 04H is function code, 02H is byte, xxH, xxH are high and low byte of returned wind speed data, e.g. 01H, 31H it is 305, indicate wind speed 30.5m/s, CRCH, CRCL are high and low of previous five returned bytes' CRC check code.

1.1.3 Instruction of wind speed sensor query address is 21H

PC command: 21H 04H 00H 06H 00H 01H D6H ABH

Sensor response: 21H 04H 02H xxH xxH CRCL CRCH

1.2 Query Wind direction data

1.2.1 Data definition (default address: 23H):

PC Command: xxH 04H 00H 07H 00H 01H CRCL CRCH

Sensor Response: xxH 04H 02H xxH xxH CRCL CRCH

1.2.2 Byte definition

xxH is slave address in the command, 04H is function code, 00H, 07H are the high and low address of the first register, 00H, 01H are the high and low quantity of register, CRCH, CRCL are the high and low of previous six bytes' CRC check code.

xxH is salve address in the response, 04H is function code, 02H is byte, xxH, xxH are high and low byte of returned wind speed data, e.g. 0AH, F0H is 2800, indicate wind direction 280°, CRCH, CRCL are high and low of previous five returned bytes' CRC check code.

1.2.3 Instruction of wind direction sensor query address is 23H

PC command: 23H 04H 00H 07H 00H 01H 86H 89H

Sensor response: 23H 04H 02H xxH xxH CRCL CRCH

1.3 Modify address command

1.3.1 Data definition

PC command: xxH 06H 00H 00H 00H xxH CRCL CRCH

Sensor response: xxH 06H 00H 00H 00H xxH CRCL CRCH

1.3.2 Byte definition

xxH is original address in the command, 06H is function code, 00H, 00H are the address register, 00H, xxH are the new address(01H~7FH can be used), CRCH, CRCL are the high and low of previous five bytes' CRC check code.

xxH is new salve address in the response, 06H is function code, 00H, 00H are the address register; 00H xxH are the new address, CRCH, CRCL are high and low of previous five returned bytes' CRC check code.

1.3.3 Instruction of sensor address change from 21H to 01H

PC command: 21H 06H 00H 00H 00H 01H 4FH 6AH

Sensor response: 01H 06H 00H 00H 01H 48H 0AH

1.4 Broadcast to return factory setting command

1.4.1 Data definition:

Command: 00H 06H 00H 00H 21H 23H D1H 92H

1.4.2 Byte definition

00H is broadcast address in the command, 06H is function code, 00H, 00H are the address register, 21H, 23H are the default address of sensor(wind speed sensor default address is 21H, wind direction sensor default address is 23H), 92H, D1 are the high and low of previous six bytes' CRC check code.

1.5 Broadcast to modify baud rate command

1.5.1 Data definition

PC Command: 00H 06H 00H 01H 00H 0xH CRCL CRCH

1.5.2 Byte definition

00H is broadcast address in the command, 06H is function code, 00H, 01H are the address register, 00H, 0xH are the baud rate setting value of sensor(baud rate 00H=2400 bit/s, 01H=4800 bit/s, 02H=9600 bit/s, 03H=19200 bit/s), CRCH, CRCL are the high and low of previous six bytes' CRC check code.

1.5.3 Instruction of Baud rate change to 4800bps

PC Command: 00H 06H 00H 01H 00H 01H 18H 1BH

2 Additional instruction

2.1 Please mark when modified the address, one bus can connect to 32 slave devices.

2.2 Error address and command not be responded. .

2.3 CRC check uses ANSI CRC16: polynomial is $X^{16}+X^{15}+X^2+1$.

2.4 Interval is not less than 300ms between two frames.

2.5 All slave devices execute broadcast command, but they do not response data.

Output characteristic curve

Current output:

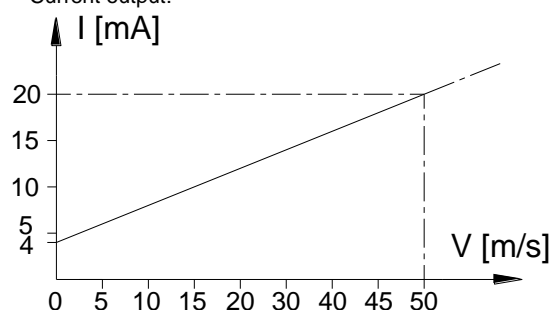

FA17 IceFree Wind Speed Sensor



How to Order

P/N	Model	Rated voltage	Signal output	Heating	Mount
1000369-001	FA173	DC18V-DC30V	4-20mA current, 0-50m/s	Heating ($\leq 90W$)	$\varnothing 50$ mast tube mount/Adapter mount, $\varnothing 30$ hole, 7 core aviation socket
1000369-002	FA174	DC5V-DC30V	RS485 current, 0-70m/s	Heating ($\leq 90W$)	$\varnothing 50$ mast tube mount/Adapter mount, $\varnothing 30$ hole, 7 core aviation socket

Thanks for choosing our products, NANHUA Electronics is the professional brand of signal transmission and high quality industrial lighting which is trusted and loved by global users from various industries. Read and understand these instructions completely and carefully. Wrong installation and operation may lead to fires, electric shock, and others. Due to our continued efforts to improve our products, product specifications are subject to change without notice.

©NANHUA Electronics Co., Ltd. All rights reserved. www.nanhua.com